

# 90° Electric Actuators

## Model 50844 Electric actuator 90° - IP68



### Specifications

#### Available voltages:

100V to 240V AC and 100V to 350V DC

15V to 30V AC and 12 to 48V DC

Three-phase 400V

**Protection rating:** IP68

**Duty cycle:** S4 50% (IEC34 standard)

150 starts/hour

**Operating temperature:** - 20°C to +70°C

**Material:** aluminium housing and plastic cap

## Product details

<b>Visual position indicator</b>	Customisable (VR) and spherical sight glass (VS)
<b>Control device</b>	On-off or 3 variable points
<b>Voltage range</b>	15V to 30V AC (50/60Hz) and 12V to 48V DC 100V to 240V AC (50/60Hz) and 100V to 350V DC Three-phase 400V (50/60Hz)
<b>Duty cycle</b>	Service S4 - 50% (IEC34 standard)
<b>Torque limiting device</b>	Computer software
<b>Connection</b>	RS485
<b>Number of starts/hour</b>	150
<b>Information transfer relays</b>	Safety mode (torque, temperature etc.)
<b>Anti-condensation resistance</b>	Self-adjusting
<b>Drive</b>	Star shape
<b>Removable fixing plates (ISO 5211)</b>	VR : F05- F07 VS : F07-F10
<b>Number of limit switches</b>	4 configurable switches (max. 5A)
<b>Manual override</b>	Clutch disengagement and protruding shaft (VR) / handwheel (VS)
<b>Mechanical end stops</b>	90°
<b>Electrical connection</b>	2 ISO M20
<b>Temperature</b>	-20°C to +70°C
<b>Protection</b>	IP68
<b>Manufacturer guarantee</b>	3 years or 50,000 movements

Options on request: aluminium cap, 1 or 2 M12 3 Poles + 1 Earth connector(s), Bluetooth communication module (except for VT600, VT1000 and three-phase 400V)

## Product data (VT model)

<b>Visual position indicator</b>	Spherical sight glass
<b>Control device</b>	3 variable points
<b>Voltage range</b>	230V AC (50/60 Hz) Three-phase 400V 50 Hz
<b>Duty cycle</b>	Service S4 - 50% (IEC34 standard)
<b>Torque limiting device</b>	Mechanical
<b>Number of starts/hour</b>	50
<b>Information transfer relays</b>	Safety mode (torque)
<b>Anti-condensation resistance</b>	Self-adjusting
<b>Drive</b>	Star 36
<b>Removable fixing plates (ISO 5211)</b>	F10-F12
<b>Number of limit switches</b>	4 configurable switches (max. 5A)
<b>Manual override</b>	Handwheel
<b>Mechanical end stops</b>	90°
<b>Electrical connection</b>	2 ISO M20
<b>Temperature</b>	-20°C to +70°C
<b>Protection</b>	IP68
<b>Manufacturer guarantee</b>	3 years or 50,000 movements

Options on request: 1 or 2 M12 3 Pole + 1 Earth connector(s)

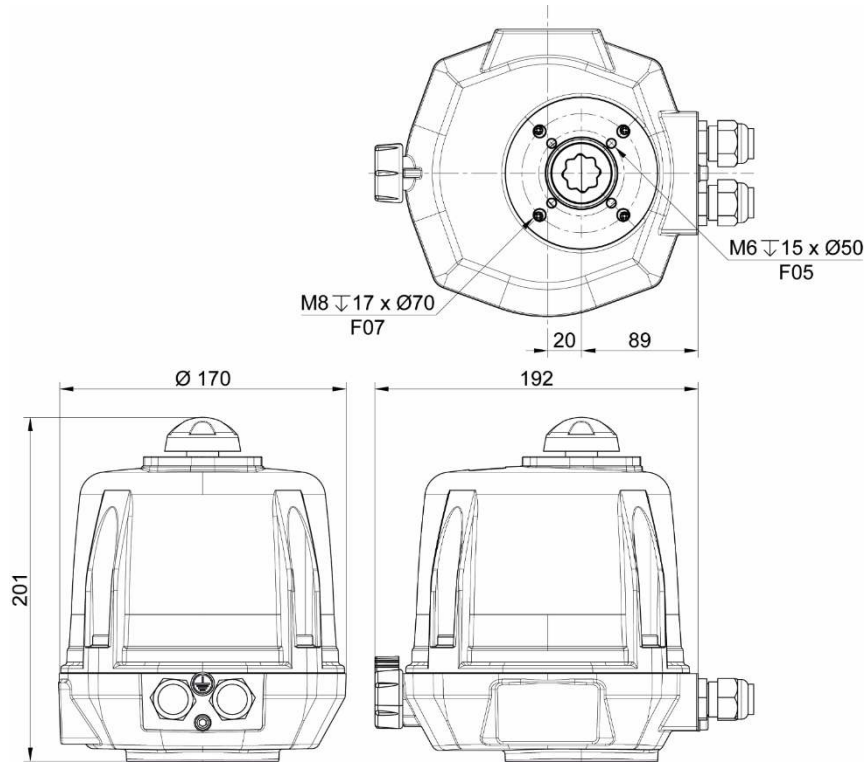

**VR model**

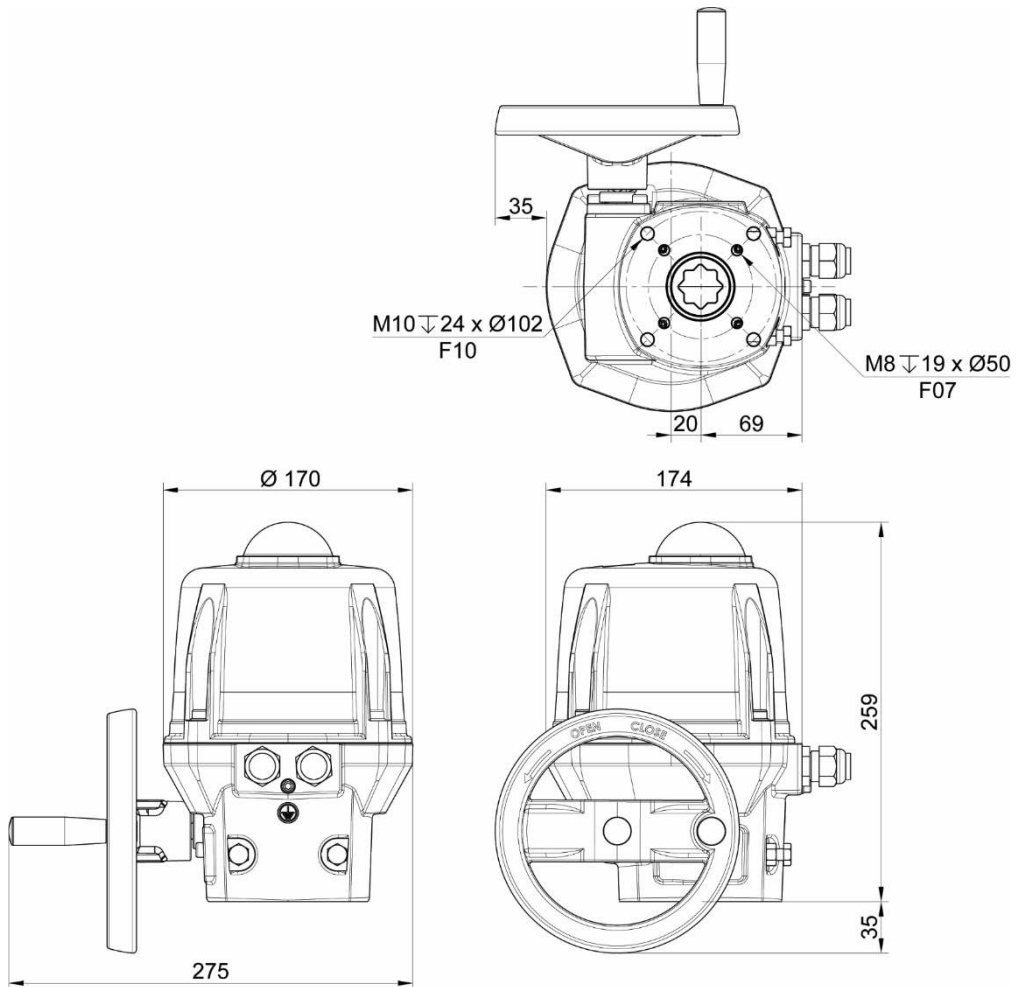

**VS model**

**Béné Inox** – 11 chemin de la Pierre Blanche – 69800 SAINT-PRIEST – S.A.S with 240 000 € share capital – SIREN N° 311 810 287  
Tel. N°: +33 (0)4 78 90 48 22 – Fax N°: +33 (0)4 78 90 69 59 – [www.bene-inox.com](http://www.bene-inox.com) – [bene@bene-inox.com](mailto:bene@bene-inox.com)

Technical information, illustrations and photographs are provided for information only, they are not contractual. Some may vary according to the tolerances accepted in the profession and the applicable standards. All instructions for use, disassembly and maintenance are recommendations only. These could also vary depending on product usage conditions, its installation environment and purchaser requirements – of which the purchaser alone is responsible for their definition.

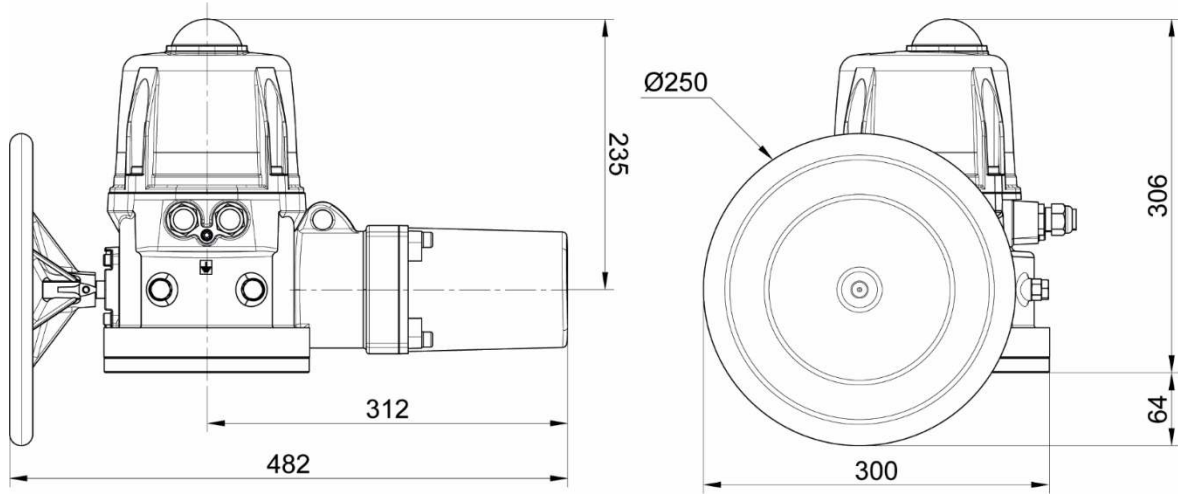
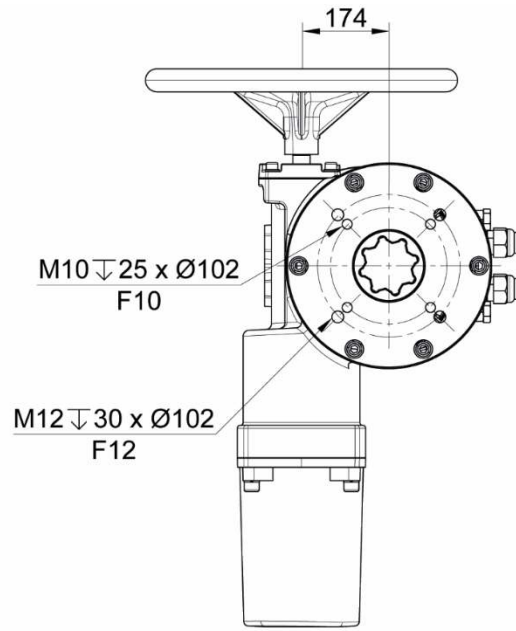

**VT model**

### 100V to 240V 50/60Hz and 100V to 350V DC

Part Name	Torque (N.m)	Power (W)	Opening/closing time (90°) (s)	ISO Mounting plate	Drive (star) (mm)	Drive depth (mm)	Weight (kg)	Part Number
VR25A	25	45	7	F05 / F07	17	19	3.50	950844-25A
VR45A	45	45	15	F05 / F07	17	19	3.50	950844-45A
VR75A	75	45	20	F05 / F07	17	19	3.50	950844-75A
VS100A	100	45	15	F07 / F10	22	25	5.50	950844-100A
VS150A	150	45	30	F07 / F10	22	25	5.50	950844-150A
VS300A	300	45	60	F07 / F10	22	25	5.50	950844-300A

### 15V to 30V 50/60Hz and 12V to 48V

Part Name	Torque (N.m)	Power (W)	Opening/closing time (90°) (s)	ISO Mounting plate	Drive (star) (mm)	Drive depth (mm)	Weight (kg)	Part Number
VR25B	25	45	7	F05 / F07	17	19	3.50	950844-25B
VR45B	45	45	15	F05 / F07	17	19	3.50	950844-45B
VR75B	75	45	20	F05 / F07	17	19	3.50	950844-75B
VS100B	100	45	15	F07 / F10	22	25	5.50	950844-100B
VS150B	150	45	30	F07 / F10	22	25	5.50	950844-150B
VS300B	300	45	60	F07 / F10	22	25	5.50	950844-300B

### Three-phase 400V 50/ 60 Hz

Part Name	Torque (N.m)	Power (W)	Opening/closing time (90°) (s)	ISO Mounting plate	Drive (star) (mm)	Drive depth (mm)	Weight (kg)	Part Number
VR259	25	52	10	F05 / F07	17	19	3.50	950844-25C
VR459	45	52	10	F05 / F07	17	19	3.50	950844-45C
VR759	75	52	15	F05 / F07	17	19	3.50	950844-75C
VS1009	100	135	10	F07 / F10	22	25	5.50	950844-100C
VS1509	150	135	20	F07 / F10	22	25	5.50	950844-150C
VS3009	300	135	35	F07 / F10	22	25	5.50	950844-300C
VT6009	600	250	38	F10 / F12	36	41	22.00	950844-600C
VT10009	1000	250	38	F10 / F12	36	41	22.00	950844-1000C

### 230V 50/60 Hz

Part Name	Torque (N.m)	Power (W)	Opening/closing time (90°) (s)	ISO Mounting plate	Drive (star) (mm)	Drive depth (mm)	Weight (kg)	Part Number
VT6008	600	250	38	F10 / F12	36	41	22.00	950844-600A
VT10008	1000	250	38	F10 / F12	36	41	22.00	950844-1000A

**Béné Inox** – 11 chemin de la Pierre Blanche – 69800 SAINT-PRIEST – S.A.S with 240 000 € share capital – SIREN N° 311 810 287  
Tel. N°: +33 (0)4 78 90 48 22 – Fax N°: +33 (0)4 78 90 69 59 – [www.bene-inox.com](http://www.bene-inox.com) – [bene@bene-inox.com](mailto:bene@bene-inox.com)

Technical information, illustrations and photographs are provided for information only, they are not contractual. Some may vary according to the tolerances accepted in the profession and the applicable standards. All instructions for use, disassembly and maintenance are recommendations only. These could also vary depending on product usage conditions, its installation environment and purchaser requirements – of which the purchaser alone is responsible for their definition.

## SAFETY INFORMATION



### You must read this information before installing this product

- You must turn off the electric power supply before you carry out any maintenance on the electric actuator (before you disassemble its cover or use the manual override).
- Any maintenance or removal/installation of the electric actuator must be carried out by a qualified electrician or a person who is fully trained in electrical engineering rules, safety rules and all other applicable regulations.
- You must respect the order of the steps for the electric actuator's connection and commissioning that are described in the user guide. If you do not do this we cannot guarantee that the actuator will work correctly. Check the information on the actuator's identification label: your electrical power supply network must correspond to these requirements.
- Do not install the actuator "head down" as this could cause the following problems:
  - The clutch disengagement mechanism could stop working correctly
  - Grease could leak onto the electronic part of the actuator
- You must install the actuator at least 30cm away from any sources of electromagnetic interference.
- Make sure you position the actuator so that it is easy to operate the circuit breaker.

## Electric circuit diagram (VR and VS)

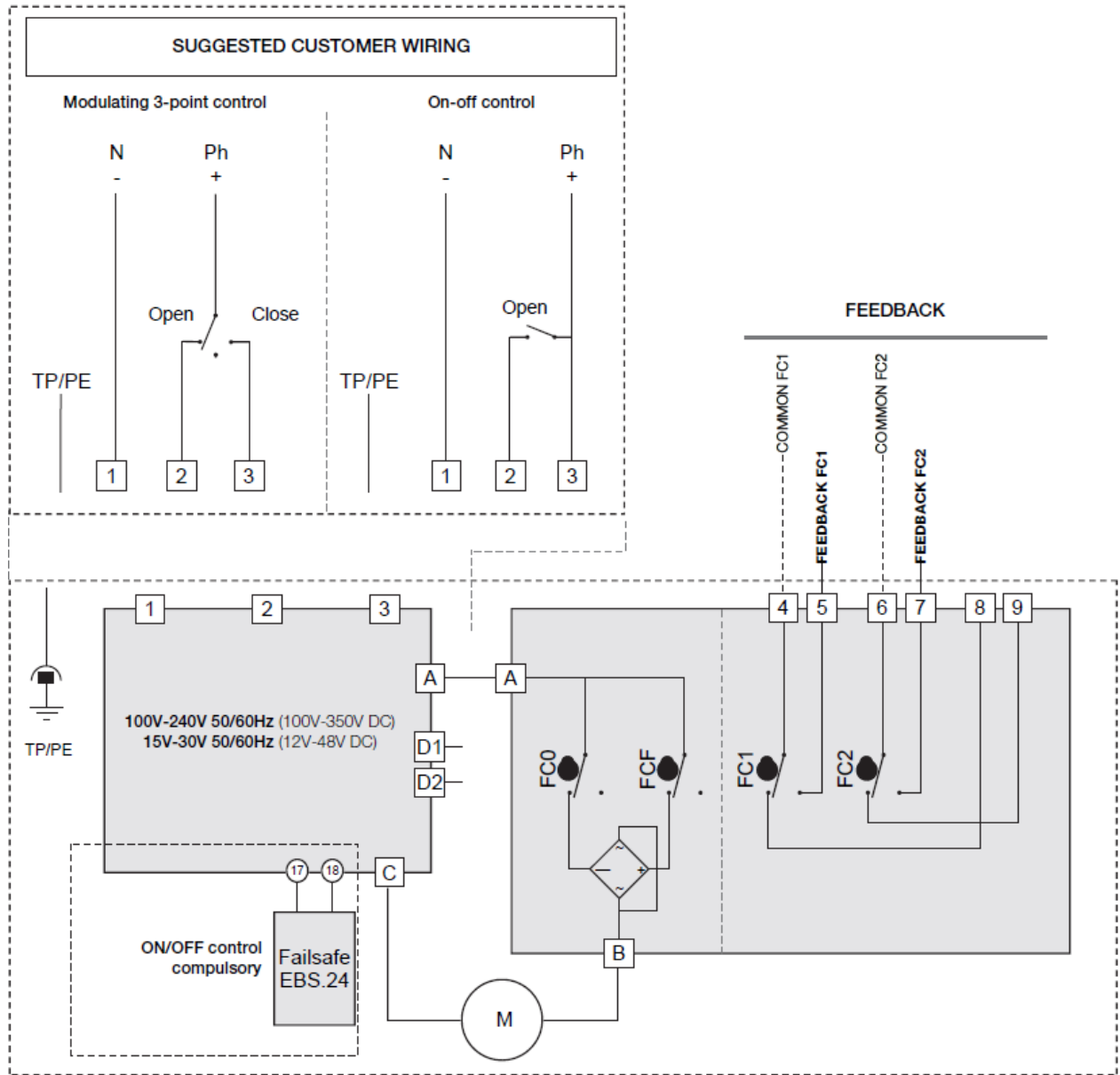

N°	Part Name
FCO	Open limit switch
FC1	Auxiliary limit switch 1
FC2	Auxiliary limit switch 2
FCF	Close limit switch
D1 / D2	Failure report terminal strip (24V DC / max. 3A)



## Electric circuit diagram three-phase 400V (VR and VS)

POWER SUPPLY (400V 3-phase 50/60Hz)

CONTROL (230V AC)

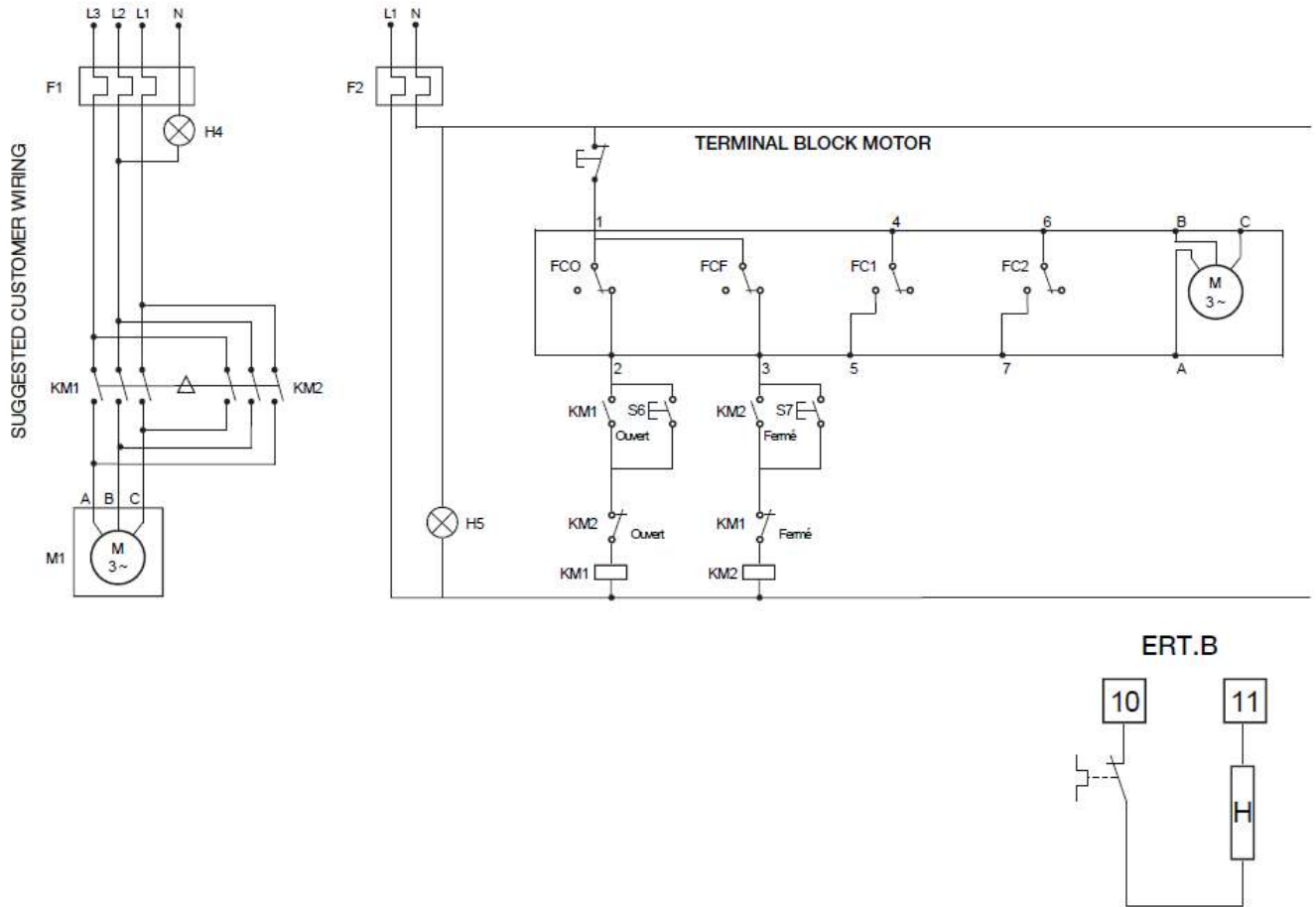

N°	Part Name	N°	Part Name
FCO	Open limit switch	H4	Motor power supply indication
FCF	Close limit switch	H5	Control power supply indication
FC1	Auxiliary limit switch 1	KM1	Opening switch
FC2	Auxiliary limit switch 2	KM2	Closing switch
F1 / F2	Thermal contact	M	Motor
S5	Emergency stop button	S7	Closing button
S6	Opening button	H	Heating resistor



The terminal strip temperature can reach 90°C

## Electric circuit diagram 230 VAC (VT)

### POWER SUPPLY AND CONTROL

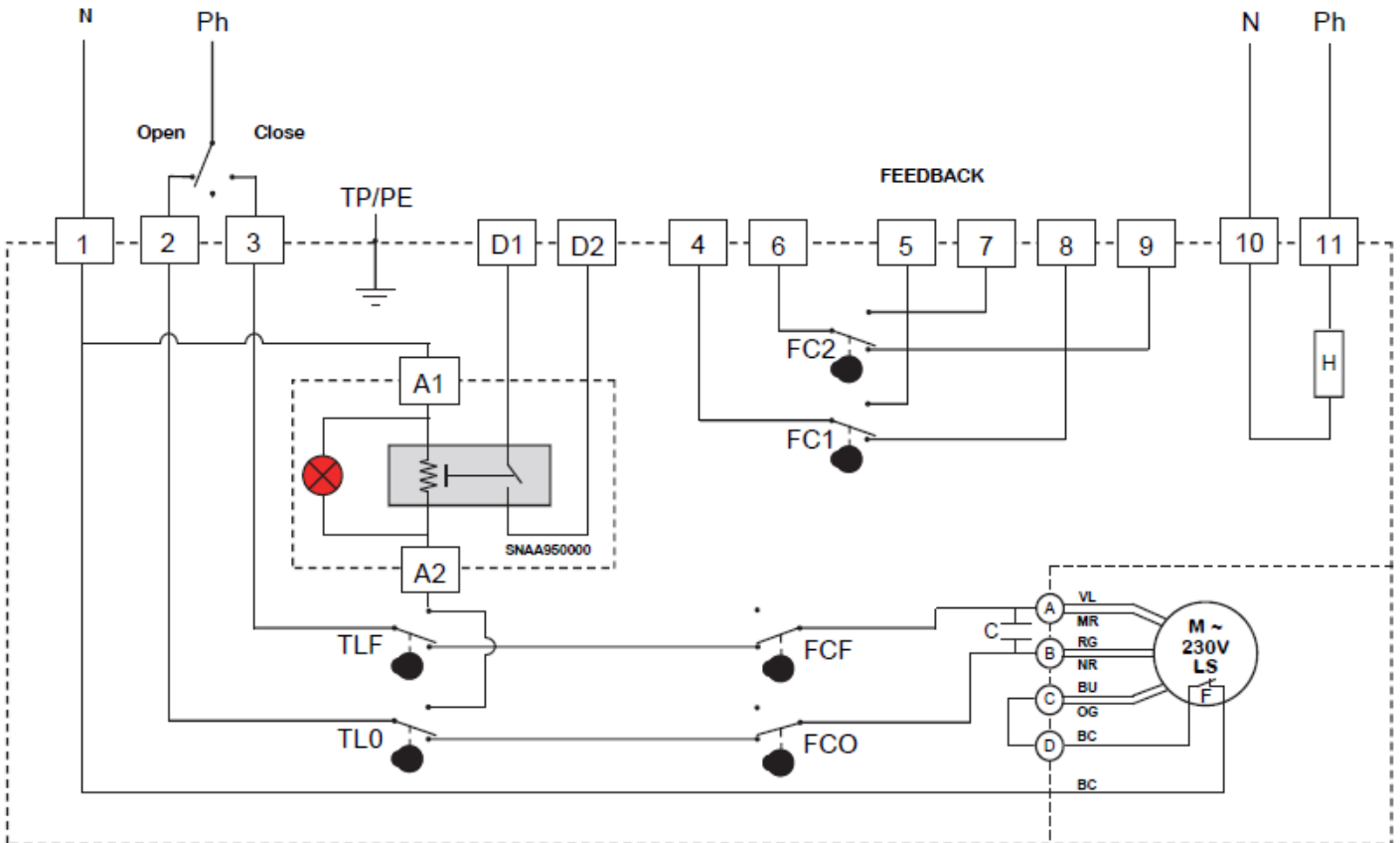

N°	Part Name	N°	Part Name
FCO	Open limit switch	VL	Purple
FC1	Auxiliary limit switch 1	NR	Black
C	Capacitor	BC	White
M	Motor	TLO	Torque switch: open
RG	Red	TLF	Torque switch: closed
OG	Orange	H	Anti-condensation resistance
FCF	Closed limit switch	MR	Brown
FC2	Auxiliary limit switch 2	BU	Blue
F	Motor thermal contact	D1/D2	Failure report terminal strip (max. 230V AC / 5 A)



The terminal strip temperature can reach 90°C

## Electric circuit diagram three-phase 400V (VT)

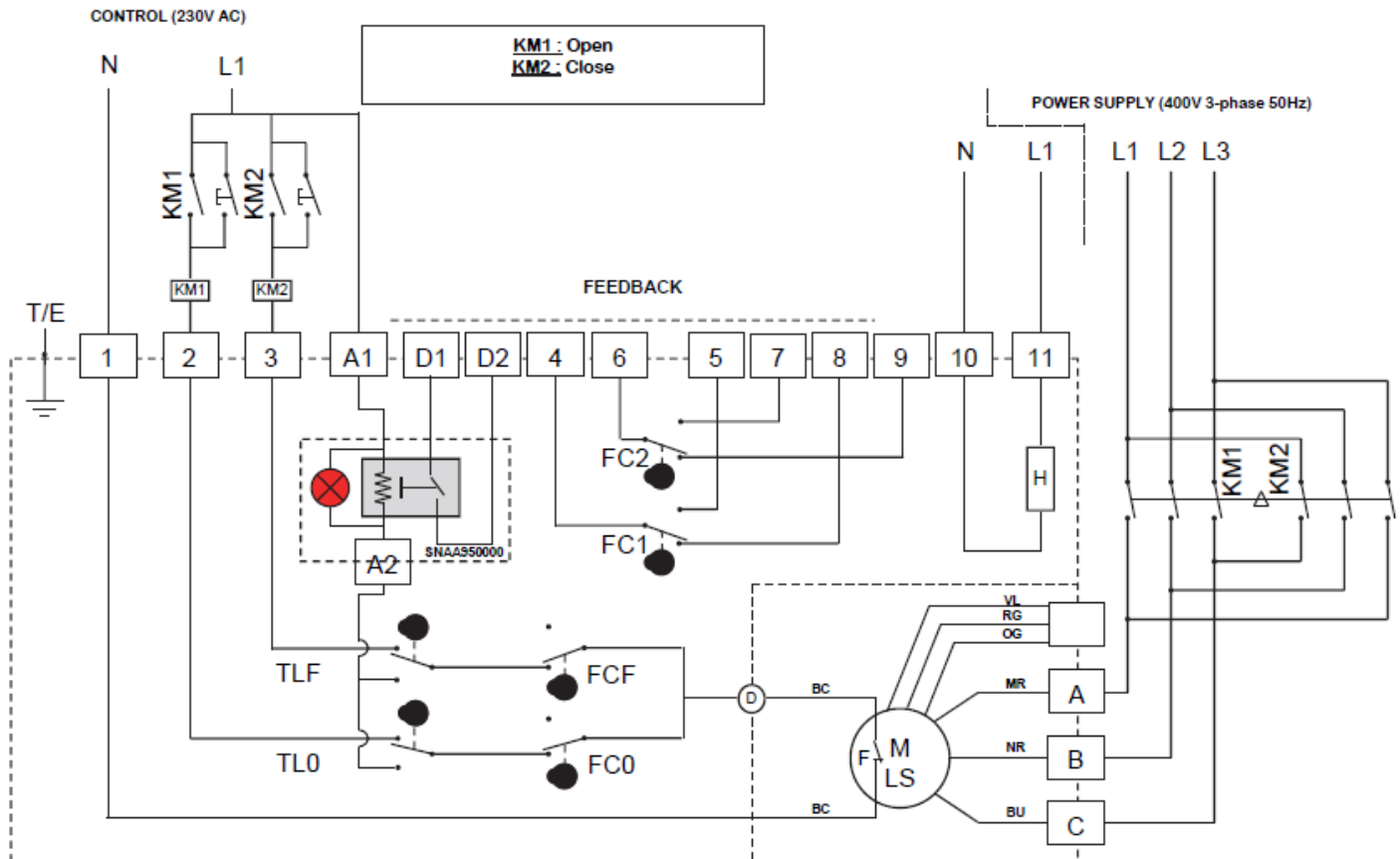

N°	Part Name	N°	Part Name
FCO	Open limit switch	VL	Purple
FC1	Auxiliary limit switch 1	NR	Black
BC	White	D1/D2	Failure report terminal strip (max. 230V AC / 5 A)
M	Motor	TLO	Torque switch: open
RG	Red	TLF	Torque switch: closed
OG	Orange	H	Anti-condensation resistance
FCF	Closed limit switch	MR	Brown
FC2	Auxiliary limit switch 2	BU	Blue
F	Thermal switch for motor		



The terminal strip temperature can reach 90°C

## Electrical connections

---

- You must only use one relay per actuator.
- You must connect an Earth plug if the actuator is used with a voltage above 42V, according to the current standards.
- As the actuator is permanently connected to a power supply, it must be connected to a circuit-breaking device (e.g. a power switch, circuit breaker) which can turn off the power supply to the actuator. You should place this near to the actuator in a position that is easy to access and clearly mark it as the actuator's power-off switch.
- The terminal strip temperature can reach 90°C.
- In order to optimise the installation's safety, you are strongly advised to connect the failure report strip (D1 and D2).
- If you want to use the device with long wires, you need to make sure that the induced current generated by the wires does not exceed 1mA.
- The actuator will accept temporary excess voltages up to  $\pm 10\%$  of the nominal operating voltage in the electrical supply NETWORK.
- Wiring selection and wiring input: You need to make sure that the maximum service temperature of the wires and cable glands is at least 110°C.
- You must connect all of the actuators to an electric control cabinet. The electrical supply wiring must be RATED for the maximum current that the device can be used at and the wiring used must comply with CEI 60227 or CEI 60245.
- You must use cable glands (7mm and 12mm wiring) to ensure IP68 watertightness. If this is not the case, replace the cable glands with ISO M20 IP68 caps. A cable gland is considered to be watertight when it has been tightened one turn after the connecting point and the external screw have come into contact.
- The auxiliary limit switches must be connected with rigid wires. If the applied voltage is greater than 42V, the user must include a fuse in the electrical supply line.
- The voltage applied to each feedback switch must be the same. The reinforced isolation of the motor control allows voltages up to 250V AC/DC.