

# Solenoid valves

**Model 50900** Electrovalve (NC) with pressure aided drive, BSP female threaded, FPM diaphragm - I.4408 stainless steel



## Specifications

- Dimensions:** DN10 to DN50 (3/8" to 2")
- Connection:** BSP female thread in accordance with ISO 228-1
- Pressure:** 10 bar
- Fluid temperature:** -10°C to +90°C
- Ambient temperature:** -10°C to +60°C
- Coil protection:** IP 65
- Material:** I.4408 body / FPM diaphragm

On request: EPDM diaphragm



**Béné Inox** – 11 chemin de la Pierre Blanche – 69800 SAINT-PRIEST – S.A.S with 240 000 € share capital – SIREN N° 311 810 287 Tel. N°: +33 (0)4 78 90 48 22 – Fax: +33 (0)4 78 90 69 59 – [www.bene-inox.com](http://www.bene-inox.com) – [bene@bene-inox.com](mailto:bene@bene-inox.com)

Technical information, illustrations and photographs are provided for information only, they are not contractual. Some may vary according to the tolerances accepted in the profession and the applicable standards. All instructions for use, disassembly and maintenance are recommendations only. These could also vary depending on product usage conditions, its installation environment and purchaser requirements – of which the purchaser alone is responsible for their definition.

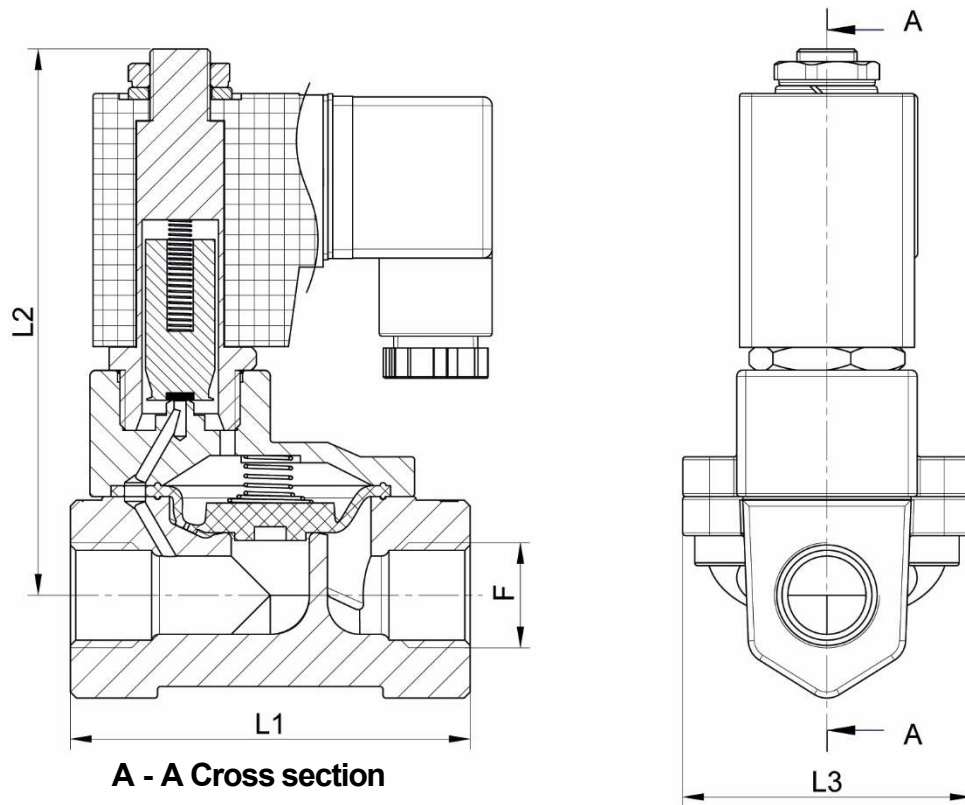

DN (mm)	NB (inches)	F (inches)	L1 (mm)	L2 (mm)	L3 (mm)	Opening/ closing time (ms)	Weight (kg)	Part number		
								230V - 50/60 Hz	24V - 50/60 Hz	24 VDC
10	3/8"	3/8"	66.5	107	48	20 - 60	0.74	450900-10A	450900-10B	450900-10C
15	1/2"	1/2"	66.5	107	48	20 - 60	0.73	450900-15A	450900-15B	450900-15C
20	3/4"	3/4"	96	126	70	20 - 60	1.43	450900-20A	450900-20B	450900-20C
25	1"	1"	96	126	70	20 - 60	1.43	450900-25A	450900-25B	450900-25C
32	1"1/4	1"1/4	131	145	96	50 - 80	2.56	450900-32A	450900-32B	450900-32C
40	1"1/2	1"1/2	131	145	96	50 - 80	2.32	450900-40A	450900-40B	450900-40C
50	2"	2"	160	161	112	50 - 80	3.44	450900-50A	450900-50B	450900-50C

**Note:**

Min./max. pressure difference: 0.5/10 bar

**Power:**

- models **450900-XXA** and **450900-XXB**: 18.1 VA
- model **450900-XXC**: 15 W

Dimensions	DN 10	DN 15	DN 20	DN 25	DN 32	DN 40	DN 50
	3/8"	1/2"	3/4"	1"	1"1/4	1"1/2	2"
<b>Cv (gal/min)</b>	3.9	3.9	10.3	10.3	18.3	24.6	39.4
<b>Kv (m³/h)</b>	3.4	3.4	8.9	8.9	15.8	21	34

**Béné Inox** – 11 chemin de la Pierre Blanche – 69800 SAINT-PRIEST – S.A.S with 240 000 € share capital – SIREN N° 311 810

287 Tel. N°: +33 (0)4 78 90 48 22 – Fax: +33 (0)4 78 90 69 59 – [www.bene-inox.com](http://www.bene-inox.com) – [bene@bene-inox.com](mailto:bene@bene-inox.com)

Technical information, illustrations and photographs are provided for information only, they are not contractual. Some may vary according to the tolerances accepted in the profession and the applicable standards. All instructions for use, disassembly and maintenance are recommendations only. These could also vary depending on product usage conditions, its installation environment and purchaser requirements – of which the purchaser alone is responsible for their definition.

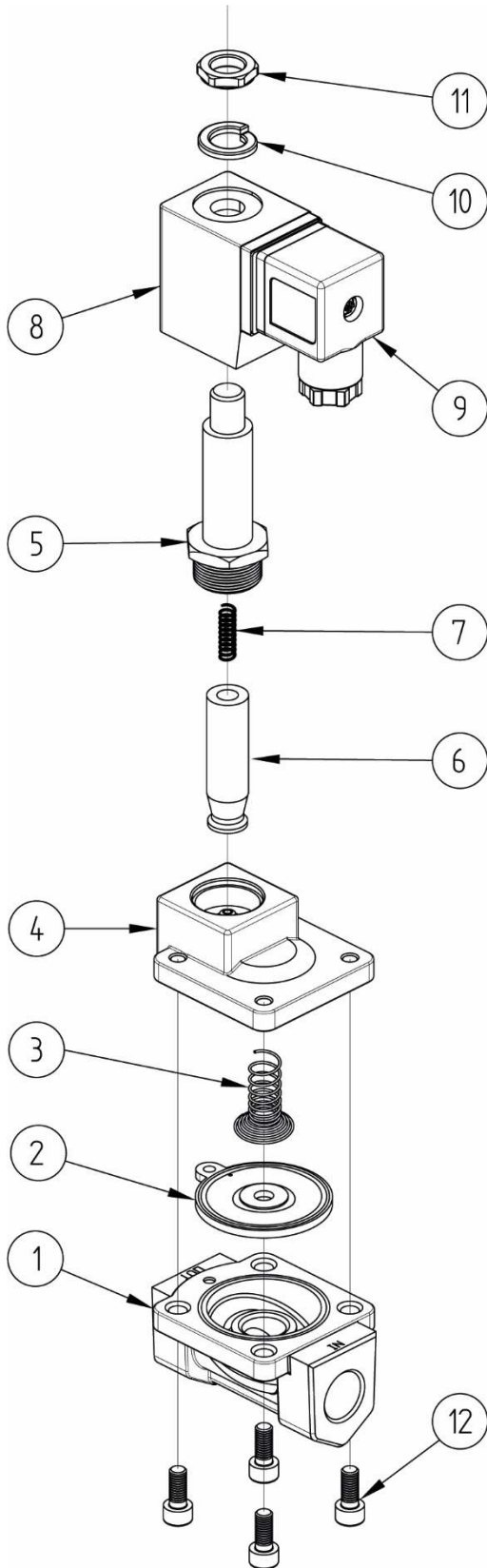

N°	Part Name	Material
1	BODY	1.4408
2	DIAPHRAGM	FPM
3	DIAPHRAGM SPRING	ALLOYED STEEL
4	CAP	1.4408
5	GUIDE TUBE	1.4301
6	CORE	STEEL
7	CONTROL SPRING	ALLOYED STEEL
8	ELECTROVALVE COIL	PBT + 30% GF
9	CONNECTOR	PLASTIC
10	FRICION WASHER	1.4301
11	NUT	NICKEL-PLATED STEEL
12	SCREW	1.4301

## Use

The electrovalve is a valve that is normally closed. It is opened when power is supplied to the coil and requires a minimum pressure difference of 0.5 bar to open correctly.

### Pressure and temperature

For pressure/temperature ratings, see the graph below.

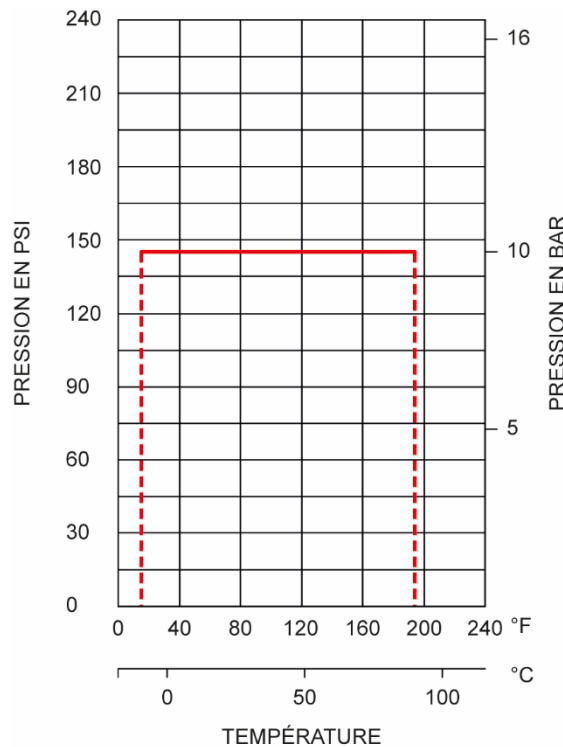

**Warning:** If the electrovalve is used with fluids that have a temperature above 60°C then people could burn themselves if they touch the electrovalve.

### Fluids

This electrovalve is suitable for non-abrasive and non-coagulable fluids, as long as the fluids are chemically compatible with the valve parts that they can come into contact with.

## Assembly and maintenance instructions

### Installation



When you install the electrovalve make sure that the arrow on its body is pointing in the direction in which fluids will pass through it (see the "IN" marking for fluid inlet and "OUT" for outlet).

Check that there is enough space to wire the electrovalve and to carry out maintenance operations where you are planning to install it.

Check that the installation is clean and free from foreign bodies that could damage the electrovalve.

Check that all piping is perfectly aligned and that the piping support structure is dimensioned so that the electrovalve is not subject to any external stresses. The piping support structure must only support the pipes, not the electrovalve's body.

#### How to install an electrovalve:

You must not use the electrovalve's body or the connector when you are tightening the assembly (this could damage the electrovalve). You must use a flat gasket, model **5296** (ISO 228-I standard) to make sure the threaded connections are correctly sealed.

Before you connect the coil, check the service conditions and the electrovalve's supply voltage (see its information panel)

If you need to, you can pivot the coil **8** on its axis by loosening the nut **11**.

### Wiring

The coils used in the electrovalve are not polarised.

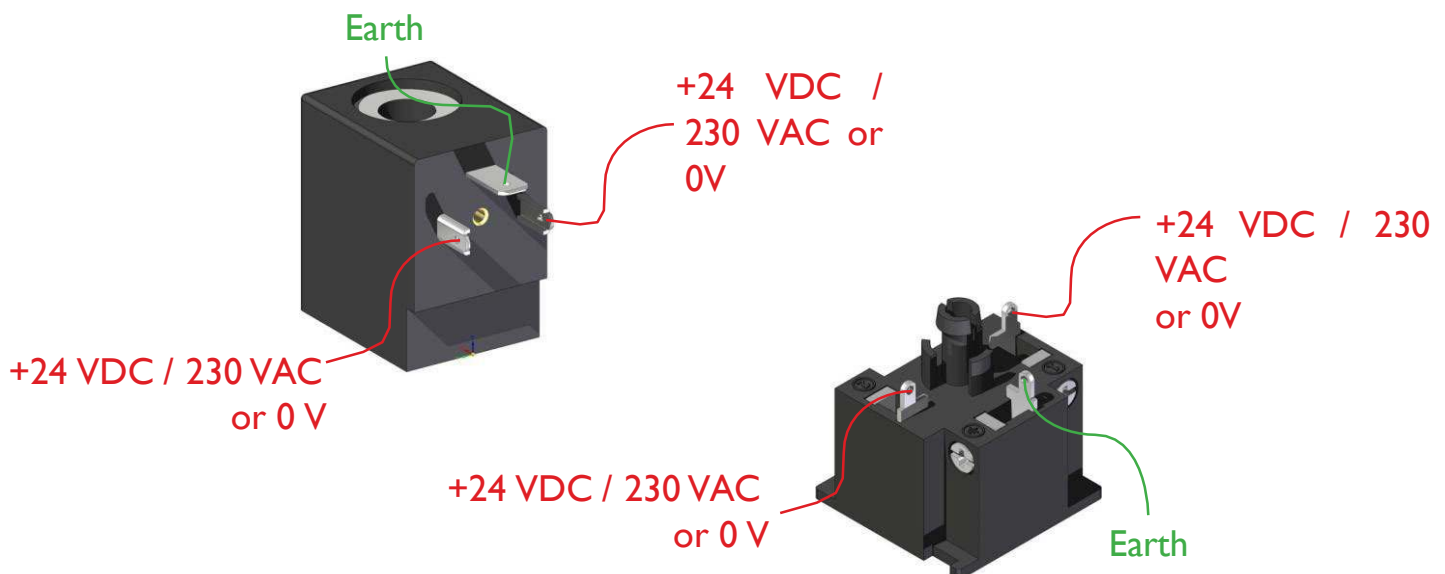

**Béné Inox** – 11 chemin de la Pierre Blanche – 69800 SAINT-PRIEST – S.A.S with 240 000 € share capital – SIREN N° 311 810 287 Tel. N°: +33 (0)4 78 90 48 22 – Fax: +33 (0)4 78 90 69 59 – [www.bene-inox.com](http://www.bene-inox.com) – [bene@bene-inox.com](mailto:bene@bene-inox.com)

Technical information, illustrations and photographs are provided for information only, they are not contractual. Some may vary according to the tolerances accepted in the profession and the applicable standards. All instructions for use, disassembly and maintenance are recommendations only. These could also vary depending on product usage conditions, its installation environment and purchaser requirements – of which the purchaser alone is responsible for their definition.

## Maintenance

The electrovalve does not require any specific maintenance if it is used in normal operating conditions.

You may need to change some of the electrovalve's parts due to unusual wear and tear, or if a fluid has damaged the valve and caused a leak or malfunction.

If this is the case see the "Assembly / Disassembly" section below.

## Assembly / Disassembly

*The maintenance and removal/installation of the electrovalve must be carried out by personnel who are qualified and trained for this type of intervention.*



Warning: Before you work on the electrovalve, check that the installation has been stopped, the piping is empty and is not pressurised and the power supply has been turned off.

Warning: If the electrovalve is used with fluids that have a temperature above 60°C then people could burn themselves if they touch the electrovalve.

Warning: Beware of hazardous materials - follow the instructions provided by the suppliers.

Unscrew the upper nut **11** from the coil **8** to remove it from the rest of the electrovalve.

Unscrew the four screws **12** from the body **1** and remove the cap **4**.

Remove the diaphragm **2**.

Clean and inspect all of the parts of the valve. Replace any worn parts.

Follow the disassembly steps in reverse order to reassemble the electrovalve.

Pressure test the electrovalve and check that it can be opened and closed before you put the installation back into service.

## Standards and compliance

- Connection: BSP female thread in accordance with EN ISO 228-1
- Leak testing according to EN 12266
- This electrovalve complies with European Pressure Equipment Directive (PED) 2014/68/EU (formerly 97/23/EC)
- This electrovalve complies with low voltage directive 2014/35/EU