

Filters

Model 58829 Flanged Y filter PN16 - 316 stainless steel



Specifications

Dimensions: DN15 to DN200 (1/2" to 8")

Connection: flanges in accordance with EN1092-1

Pressure: PN16

Temperature: - 20°C to +180°C

Material: 316 or CF8M stainless steel

With bleed plug

PTFE gaskets

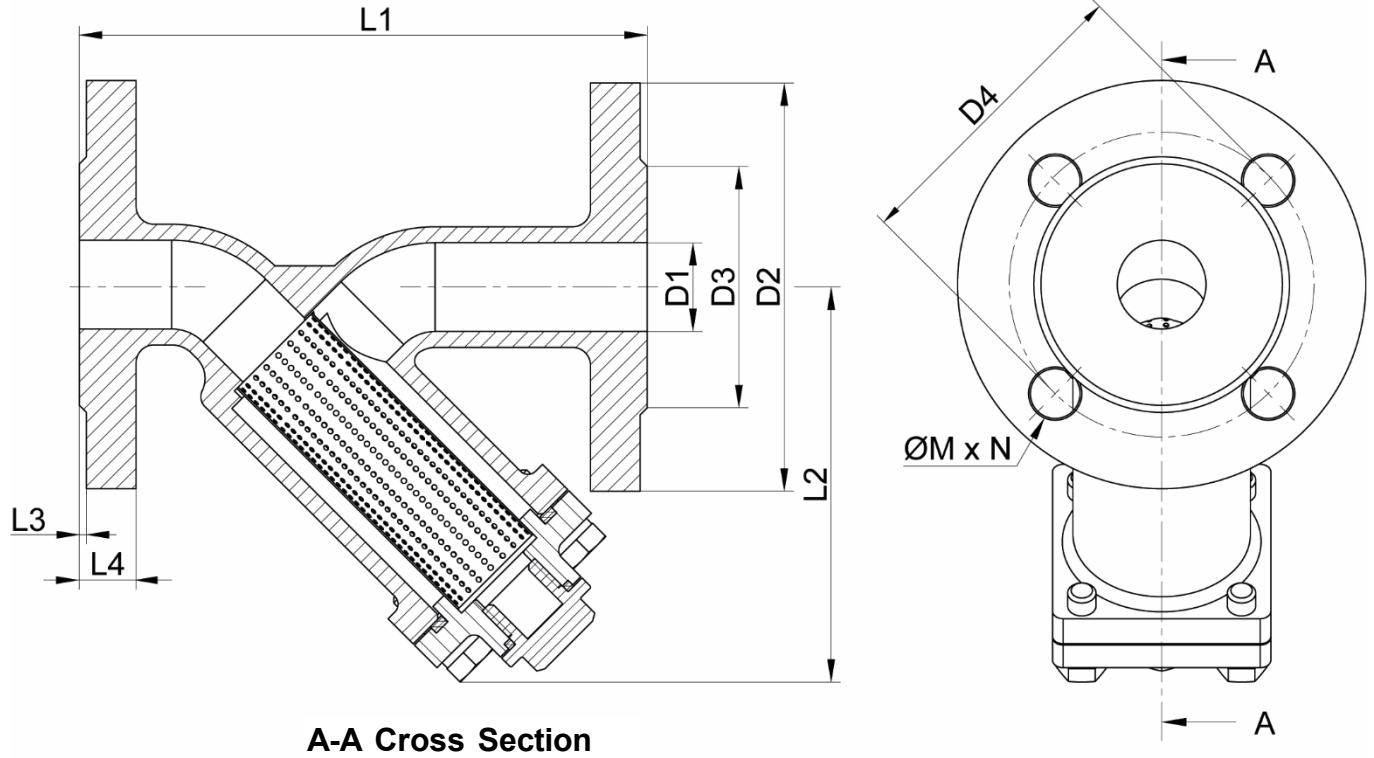

A-A Cross Section

DN (mm)	NB (inches)	D1 (mm)	D2 (mm)	D3 (mm)	D4 (mm)	L1 (mm)	L2 (mm)	L3 (mm)	L4 (mm)	ØM (mm)	N (mm)	Sieve mesh (mm)	Weight t (kg)	Part number
15	1/2"	15	95	45	65	130	75	2	14	14	4	1	2.20	458829-15
20	3/4"	20	105	58	75	150	90	2	16	14	4	1	2.70	458829-20
25	1"	25	115	68	85	160	100	2	16	14	4	1	3.60	458829-25
32	1 1/4"	32	140	78	100	180	115	2	16	18	4	1	5.10	458829-32
40	1 1/2"	40	150	88	110	200	130	3	16	18	4	1	6.02	458829-40
50	2"	50	165	102	125	230	150	3	18	18	4	1	8.99	458829-50
65	2 1/2"	65	185	122	145	290	190	3	18	18	4	2	12.81	458829-65
80	3"	80	200	138	160	310	225	3	20	18	8	2	17.36	458829-80
100	4"	100	220	158	180	350	235	3	20	18	8	2	22.00	458829-100
125	5"	125	250	188	210	400	280	3	22	18	8	2	30.40	458829-125
150	6"	150	285	212	240	480	325	3	22	22	8	2	45.10	458829-150
200	8"	200	340	268	295	605	400	3	24	22	12	2	77.10	458829-200

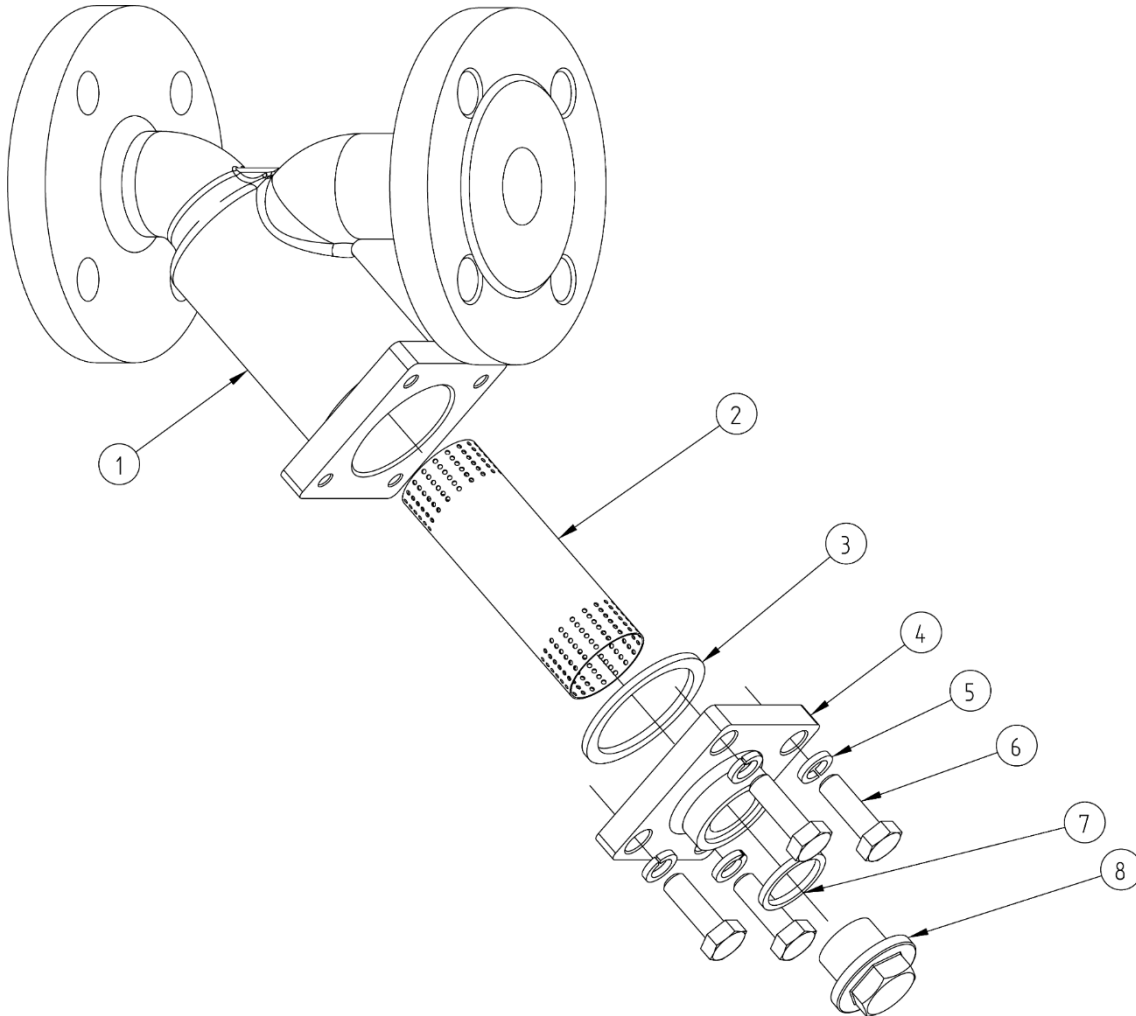

	Part Name	Material
1	BODY	ASTM CF8M
2	FINE SIEVE	AISI 316
3	CAP GASKET	PTFE
4	CAP	CF8M
5	LOCK WASHER	AISI 304
6	SCREW (CAP)	AISI 304
7	BLEED PLUG GASKET	PTFE
8	BLEED PLUG	CF8M

Use

Pressure and temperature

For pressure/temperature ratings, see the graph below.

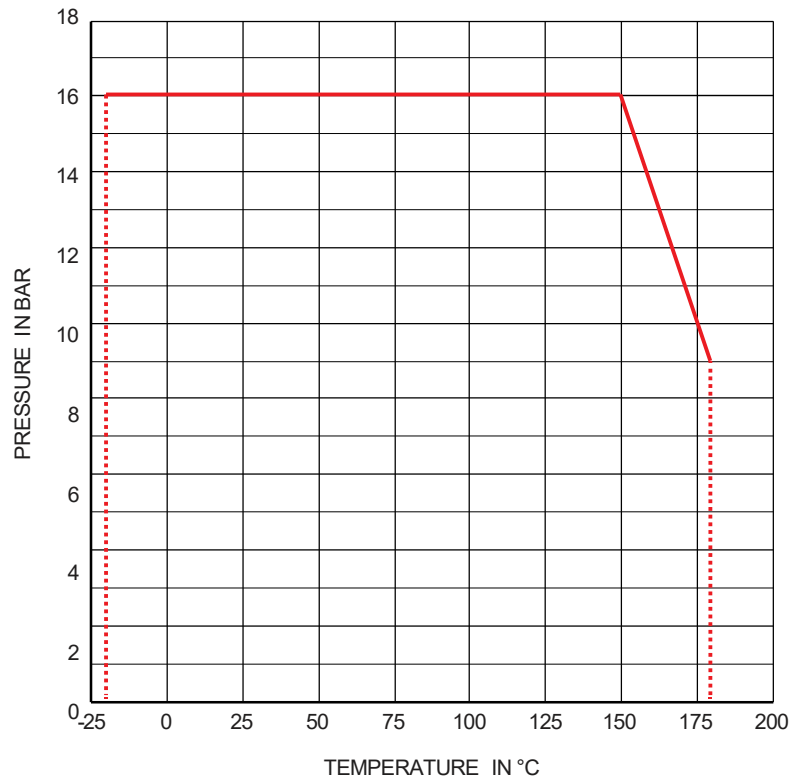

Warning: If the filter is used with fluids that have a temperature above 60°C then people could burn themselves if they touch it.

Fluids

This filter is suitable for non-coagulable fluids, as long as the fluids are chemically compatible with the filter parts that they can come into contact with.

Pressure drop

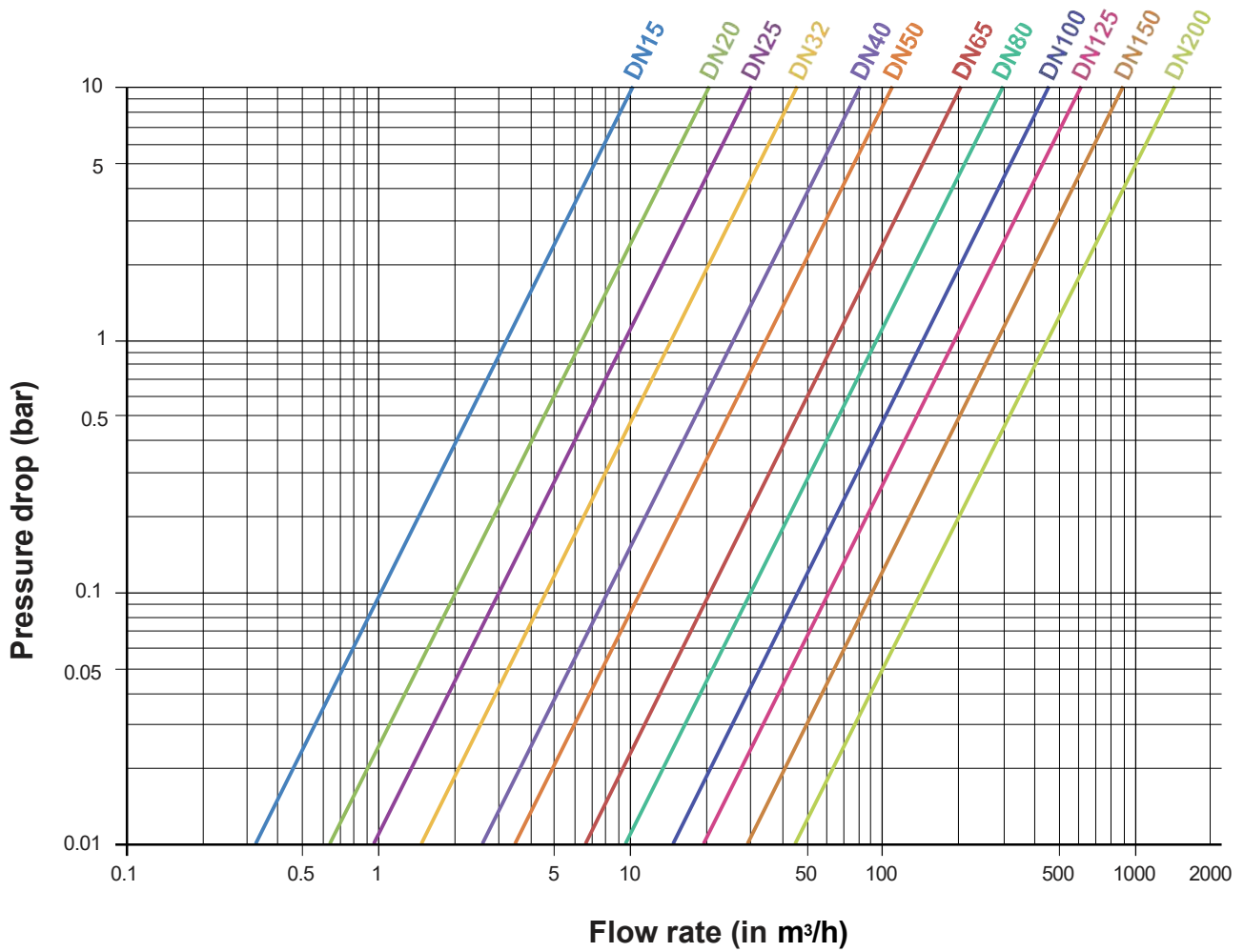

Assembly and maintenance instructions

Installation

You must take into account the direction of fluid circulation when you fit the filter (see the arrow on the filter's body). You can install the filter in any position, however, to make it easier to drain and clean the filter, you should install it on a vertical pipe with fluid moving downwards or on a horizontal pipe with the fine sieve facing downwards.

Check that there is enough space to carry out maintenance operations where you are planning to install the filter. Check that the installation is clean and free from foreign bodies that could damage the filter.

Make sure that the piping is perfectly aligned and its support structure sufficiently dimensioned so that the filter is not subject to any external stresses. The piping support structure must only support the pipes, not the filter body.

How to install the filter:

Weld flanges (e.g. flanges with collar) onto the piping and respect the required spacing and alignment of the mounting holes. You must check that the filter is correctly lined up with the flanges during installation. For heavy parts, use lifting devices if necessary.

Clean the installation so that there are no foreign bodies that could block the piping and damage the filter.

Pressure test the installation according to the applicable standards, but do not exceed the filter's specifications.

Maintenance

The maintenance and removal/installation of the filter must be carried out by personnel who are qualified and trained for this type of intervention.



Warning: Before you work on the filter check that the installation has been stopped and that the piping is empty and is not pressurised.

Warning: If the filter is used with fluids that have a temperature above 60°C then people could burn themselves if they touch it.

Warning: Beware of hazardous materials - follow the instructions provided by the suppliers.

You must clean the filter regularly as it is intended to retain impurities and foreign bodies. You must also periodically check that the sieve element (fine sieve **2**) is not blocked, as this could reduce the efficiency of the filter or even destroy it.

The frequency of this operation is to be defined by the user according to the characteristics of the fluid passing through it.

If you need to drain the filter, unscrew the bleed plug **8** and/or unscrew the cap **4** to completely remove the fine sieve for cleaning.

If any leaks appear around the PTFE gasket **3**, during operation (or during the filter installation testing phase), tighten the cap **4** with the screws **6**.

You may need to change some of the filter's parts if a fluid has damaged the valve and caused a leak or malfunction.

If this is the case follow the instructions below.

Assembly / Disassembly

Unscrew and remove the screws **6** and the washers **5**, remove the cap **4** (you must tighten and unscrew the screws in a criss-cross pattern), the bleed plug **8**, the bleed plug gasket **7**, the cap gasket **3** and the fine sieve **2**.

Clean and inspect all of the parts of the filter. Replace any worn parts. You should change all the sealing parts (gaskets) if the filter has been disassembled.

Follow the disassembly steps in reverse order to reassemble the filter.

Standards and compliance

- Leak testing according to EN 12266 / API 598
- This filter complies with European Pressure Equipment Directive (PED) 2014/68/EU (formerly 97/23/EC)
- This filter is outside of the scope of Directive 2014/34/EU as this product does not have its "own" ignition source.
(see paragraph §41 regarding "own" ignition sources in the ATEX GUIDELINES 2014/34/EU)