

MACON valves and accessories

MACON valve accessories

Model **64526**

Vacuum/Pressure relief valve - 316L stainless steel



Specifications

Dimensions: DN60 (Ø63.5mm)

Connections: plain ends for welding

Opening pressure:

- pressure: from +4 mbar to +36 mbar
- vacuum: -2 mbar

Material: 316L stainless steel
EPDM gaskets

On request: FKM gaskets (BNIC certified).



Béné Inox – 11 Chemin de la Pierre Blanche – 69800 SAINT PRIEST – S.A.S with 240 000 € share capital
SIREN N° 311 810 287 – Tel. N°: +33 (0)4 78 90 48 22 – Fax N°: +33 (0)4 78 90 69 59 – www.bene-inox.com – bene@bene-inox.com

Technical information, illustrations and photographs are provided for information only, they are not contractual. Some may vary according to the tolerances accepted in the profession and the applicable standards. All instructions for use, disassembly and maintenance are recommendations only. These could also vary depending on product usage conditions, its installation environment and purchaser requirements – of which the purchaser alone is responsible for their definition.

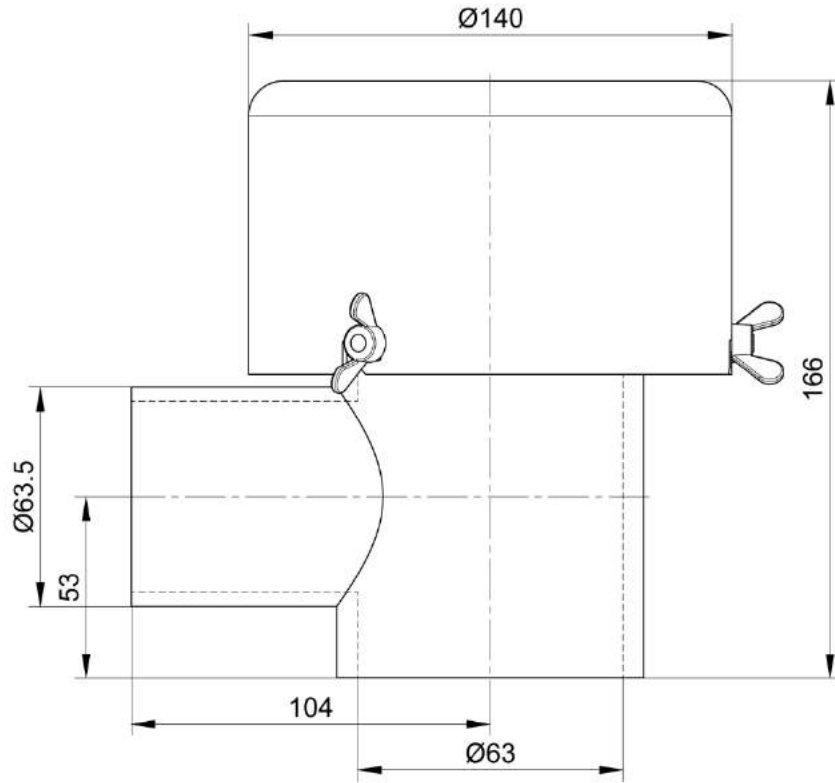

DN (mm)	Part Name	Weight (kg)	Part number
40	SDS63	5.20	664376-40

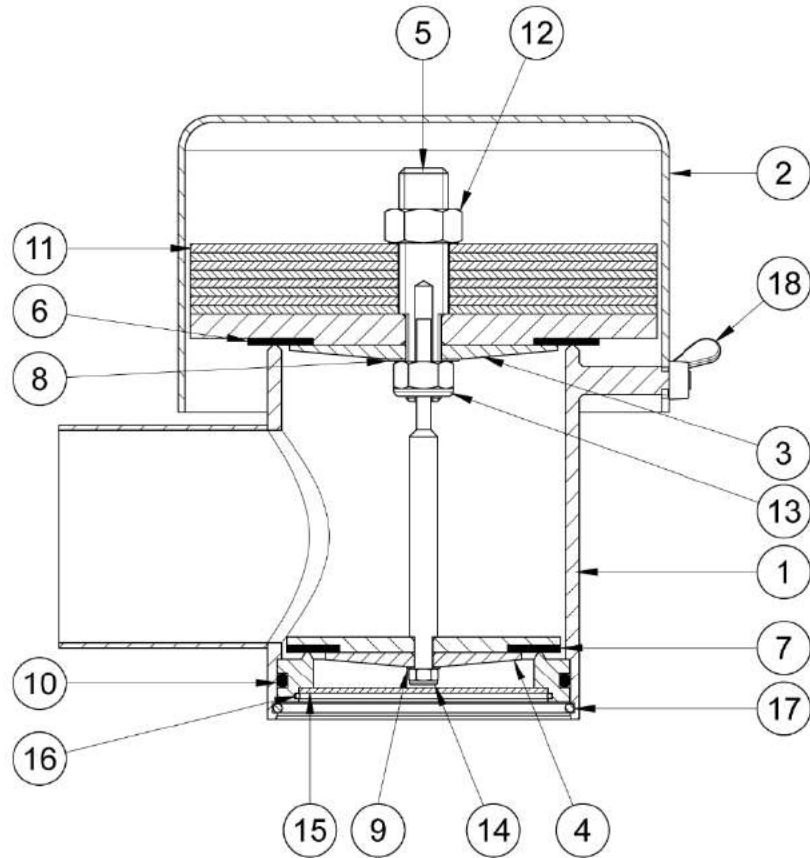

N°	Part Name	Material
1	BODY	AISI 316L
2	CAP	AISI 304L
3	PRESSURE REGULATOR VALVE	AISI 316L
4	VACUUM REGULATOR VALVE	AISI 316L
5	SHAFT (PRESSURE REGULATOR VALVE 1/2 SHAFT + VACUUM REGULATOR VALVE 1/2 SHAFT)	AISI 316L
6	FLAT GASKET (PRESSURE REGULATOR VALVE)	EPDM
7	FLAT GASKET (VACUUM REGULATOR VALVE)	EPDM
8	SEALING WASHER (PRESSURE REGULATOR VALVE)	NYLON
9	SEALING WASHER (VACUUM REGULATOR VALVE)	NYLON
10	O-RING	EPDM
11	PRESSURE SETTING WASHER (PRESSURE REGULATOR VALVE)	AISI 304L
12	SHAFT NUT	A2
13	LOCK NUT (PRESSURE REGULATOR VALVE)	A2
14	LOCK NUT (VACUUM REGULATOR VALVE)	A2
15	PROTECTIVE GRID	AISI 304L
16	GRID RETAINING CLIP	A2
17	RETAINING RING	A2
18	WING NUT	A2

Béné Inox – 11 Chemin de la Pierre Blanche – 69800 SAINT PRIEST – S.A.S with 240 000 € share capital

SIREN N° 311 810 287 – Tel. N°: +33 (0)4 78 90 48 22 – Fax N°: +33 (0)4 78 90 69 59 – www.bene-inox.com – bene@bene-inox.com

Technical information, illustrations and photographs are provided for information only, they are not contractual. Some may vary according to the tolerances accepted in the profession and the applicable standards. All instructions for use, disassembly and maintenance are recommendations only. These could also vary depending on product usage conditions, its installation environment and purchaser requirements – of which the purchaser alone is responsible for their definition.

The graph below shows the opening pressure for the pressure relief valve for different numbers of pressure setting washers and the excess internal pressure levels for different tank filling flow rates.

This graph can also be read the other way round so, for a given internal tank pressure, you can find the pressure relief valve's venting flow rate (depending on the number of pressure setting washers in it). You can also use this graph to find out information for excessive vacuums, tank emptying flow rates and vacuum relief valve inflow. You can read the graph in the same way as described above, but there are no pressure setting washers.

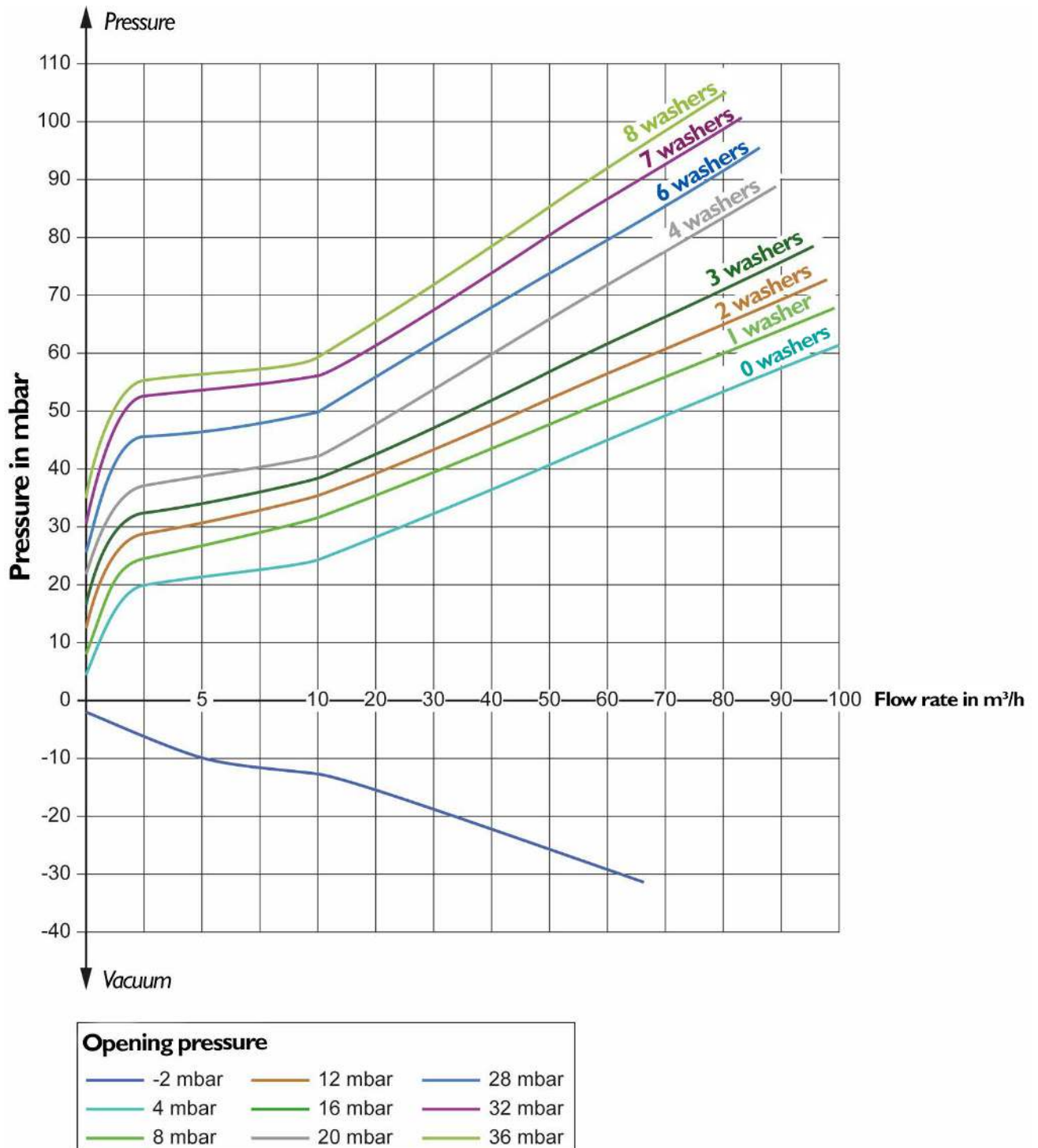

Béné Inox – 11 Chemin de la Pierre Blanche – 69800 SAINT PRIEST – S.A.S with 240 000 € share capital

SIREN N° 311 810 287 – Tel. N°: +33 (0)4 78 90 48 22 – Fax N°: +33 (0)4 78 90 69 59 – www.bene-inox.com – bene@bene-inox.com

Technical information, illustrations and photographs are provided for information only, they are not contractual. Some may vary according to the tolerances accepted in the profession and the applicable standards. All instructions for use, disassembly and maintenance are recommendations only. These could also vary depending on product usage conditions, its installation environment and purchaser requirements – of which the purchaser alone is responsible for their definition.

Use

Vacuum/pressure relief valves can be used to protect low pressure tanks that do not need to comply with the EU Pressure Equipment Directive (i.e. internal pressure is lower than 0.5 bar). These valves can be used to avoid the build-up of overpressure or excessive vacuums in storage tanks during wine making or nitrogen blanketing process steps.

Venting or outflow from these relief valves is uncontrolled.

The relief valve is delivered with 8 pressure setting washers. Each washer increases the valve's set pressure by 4mbar. See the Assembly / Disassembly section (page 6) to adjust the number of washers in the valve.

Number of washers	0	1	2	3	4	5	6	7	8
Opening pressure	4 mbar	8 mbar	12 mbar	16 mbar	20 mbar	24 mbar	28 mbar	32 mbar	36 mbar

In the case of an excessive vacuum, the opening vacuum is -2 mbar.

Fluids

This vacuum/pressure relief valve cannot be used with water-based products as they could cause gasket sticking and change the valve's opening pressure. This relief valve is specifically designed for use with gases.



Warning: If the vacuum/pressure relief valve is used with gases that have a temperature above 60°C then people could burn themselves if they touch it.

Assembly and maintenance instructions

Installation

You must install the vacuum/pressure relief valve vertically with the cap at the top.

The vacuum/pressure relief valve's shaft must be straight and the regulator valves must be horizontal for the product to work optimally.

Check that there is enough space to carry out maintenance operations where you are planning to install the vacuum/pressure relief valve.

How to install a vacuum/pressure relief valve requiring welding:

Welding must be carried out by qualified personnel. Tack weld the relief valve or use a jig to make sure that it is positioned correctly.

Clean the installation and check that the equipment is clean and free from foreign bodies that could damage the relief valve.

Béné Inox – 11 Chemin de la Pierre Blanche – 69800 SAINT PRIEST – S.A.S with 240 000 € share capital
SIREN N° 311 810 287 – Tel. N°: +33 (0)4 78 90 48 22 – Fax N°: +33 (0)4 78 90 69 59 – www.bene-inox.com – bene@bene-inox.com

Technical information, illustrations and photographs are provided for information only, they are not contractual. Some may vary according to the tolerances accepted in the profession and the applicable standards. All instructions for use, disassembly and maintenance are recommendations only. These could also vary depending on product usage conditions, its installation environment and purchaser requirements – of which the purchaser alone is responsible for their definition.

Maintenance

You may need to change some of the vacuum/pressure relief valve's parts due to wear and tear, or if a gas has damaged the valve and caused a leak or malfunction.

The user must decide if the relief valve's gaskets need to be changed during preventative maintenance and if so at what frequency, taking into account the conditions in which they will use the relief valve. See the "Assembly / Disassembly" section below for information about changing the valve's gaskets.

Assembly / Disassembly

The maintenance and removal/installation of the vacuum/pressure relief valve must be carried out by personnel who are qualified and trained for this type of intervention.

Unscrew the 3 wing nuts **18** so that you can remove the relief valve's cap **2**.
Turn the cap **2** slightly anti-clockwise and lift it to remove it.

How to adjust the pressure relief valve's opening pressure:

Unscrew the shaft nut **12**.

Remove pressure setting washers **11** so that the remaining number of washers gives the required pressure relief valve opening pressure (see the table on page 5).

How to change the vacuum/pressure relief valve's gaskets and sealing washers:

Remove the pressure regulator assembly (1/2 **5** + **12** + **11** + **6** + **3** + **8** + **13**) from the relief valve. Take the pressure regulator valve assembly and unscrew the lock nut **13** holding the sealing washer **8** and then remove it. Remove the disk from the pressure regulator valve **3** so that you can remove the flat gasket **6**.

Remove the vacuum regulator assembly (1/2 **5** + **4** + **7** + **9** + **14**).

Take the vacuum regulator valve assembly and unscrew the lock nut **14** holding the sealing washer **9** and then remove it. Remove the disk from the regulator valve **4** so that you can remove the flat gasket **7**.

Turn the valve's body **1** over and remove the retaining ring **17** using a non-sharp pointed tool (e.g. a screwdriver). Remove the clip **16** then push the grid **15** out from the inside.

Push the stainless steel part containing the o-ring **10** out from the inside so that you can remove it.

Clean and inspect all of the parts of the relief valve. Replace any worn parts. You are strongly advised to replace all of the sealing parts (**6**, **7**, **8**, **9** and **10**) if you completely disassemble the relief valve.

Follow the disassembly steps in reverse to reassemble the vacuum/pressure relief valve.

Apply Loctite 518 around the shaft **5** (on each 1/2 section) where the regulator valves **3** and **4** sit to make sure that it is completely sealed.

You can lubricate the o-ring **10** to make it easier to assemble. Make sure that the lubricant you use is chemically compatible with the EPDM gasket.

Béné Inox – 11 Chemin de la Pierre Blanche – 69800 SAINT PRIEST – S.A.S with 240 000 € share capital
SIREN N° 311 810 287 – Tel. N°: +33 (0)4 78 90 48 22 – Fax N°: +33 (0)4 78 90 69 59 – www.bene-inox.com – bene@bene-inox.com

Technical information, illustrations and photographs are provided for information only, they are not contractual. Some may vary according to the tolerances accepted in the profession and the applicable standards. All instructions for use, disassembly and maintenance are recommendations only. These could also vary depending on product usage conditions, its installation environment and purchaser requirements – of which the purchaser alone is responsible for their definition.

Spare parts

N°	Part Name	Part number
11	PRESSURE SETTING WASHER	RDL13314525
6	FLAT GASKET (PRESSURE REGULATOR VALVE)	JPL100632E (EPDM) JPL100632V (FKM)
7	FLAT GASKET (VACUUM REGULATOR VALVE)	JPL78482E (EPDM) JPL78482V (FKM)
8	SEALING WASHER	RDL95505
9	SEALING WASHER	RDL201005
10	O-RING	JTO758353E

Standards and compliance

- This valve complies with EC Directive 1935/2004.
- The FKM gasket complies with BNIC.